

B1 - START MMP motor
 B2 - STOP MMP motor
 B3 - START HIDRAULIC
 B4 - STOP HIDRAULIC
 B5 - START ROLER PRESSING
 B6 - STOP ROLER PRESSING
 B7 - EMERGENCY STOP
 B8 - ON/OFF GENERAL

B1L - LAMPA SEMNALIZARE B1
 B2L - LAMPA SEMNALIZARE B2
 B3L - LAMPA SEMNALIZARE B3
 B4L - LAMPA SEMNALIZARE B4
 B5L - LAMPA SEMNALIZARE B5
 B6L - LAMPA SEMNALIZARE B6
 B7L - LAMPA SEMNALIZARE B7
 B8L - LAMPA SEMNALIZARE B8



Folio	Title	Plants	Location	Rev	Author	Date
1/13	SWITCHES AND LAMPS CABLE MANAGEMENT			2.0	ING. TESU ADRIAN	5/24/2020
2/13	List of Folios					
3/13	MAIN MOTORS POWER			2.0	ING. TESU ADRIAN	5/24/2020
4/13	MAIN MOTOR ROLLER PRESSER				ING. TESU ADRIAN	7/4/2020
5/13	STAR-DELTA STARTUP MMP by contacts			2.0	ING. TESU ADRIAN	5/24/2020
6/13	MOTORS CONTROL MMR-MH			2.0	ING. TESU ADRIAN	5/25/2020
7/13	JOYSTICKS CONTACTS			2.0	ING. TESU ADRIAN	5/25/2020
8/13	HIDRAULICS VALVS INTERCONNECTION			2.0	ING. TESU ADRIAN	6/8/2020
9/13	INTERMEDIAR RELAY INTERCONNECTIONS				ING. TESU ADRIAN	6/8/2020
10/13	STAR-DELTA STARTUP MMP by PLC				ING. TESU ADRIAN	7/4/2020
11/13	FRONT PANNEL				ING. TESU ADRIAN	7/4/2020
12/13	MAIN CABLE CONNECTIONS				ING. TESU ADRIAN	7/4/2020
13/13	LASER BLADE GUIDE				ING. TESU ADRIAN	7/4/2020



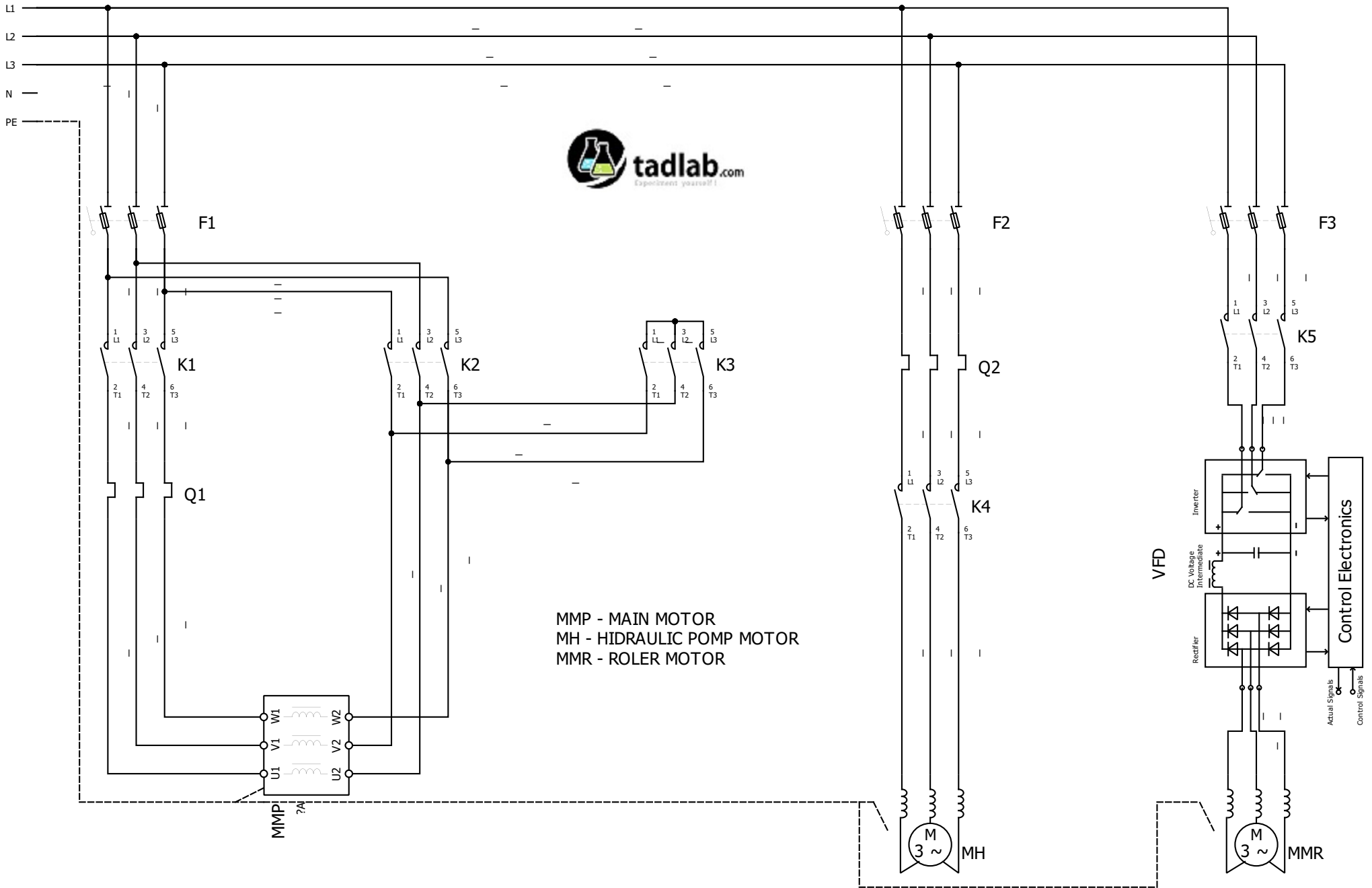

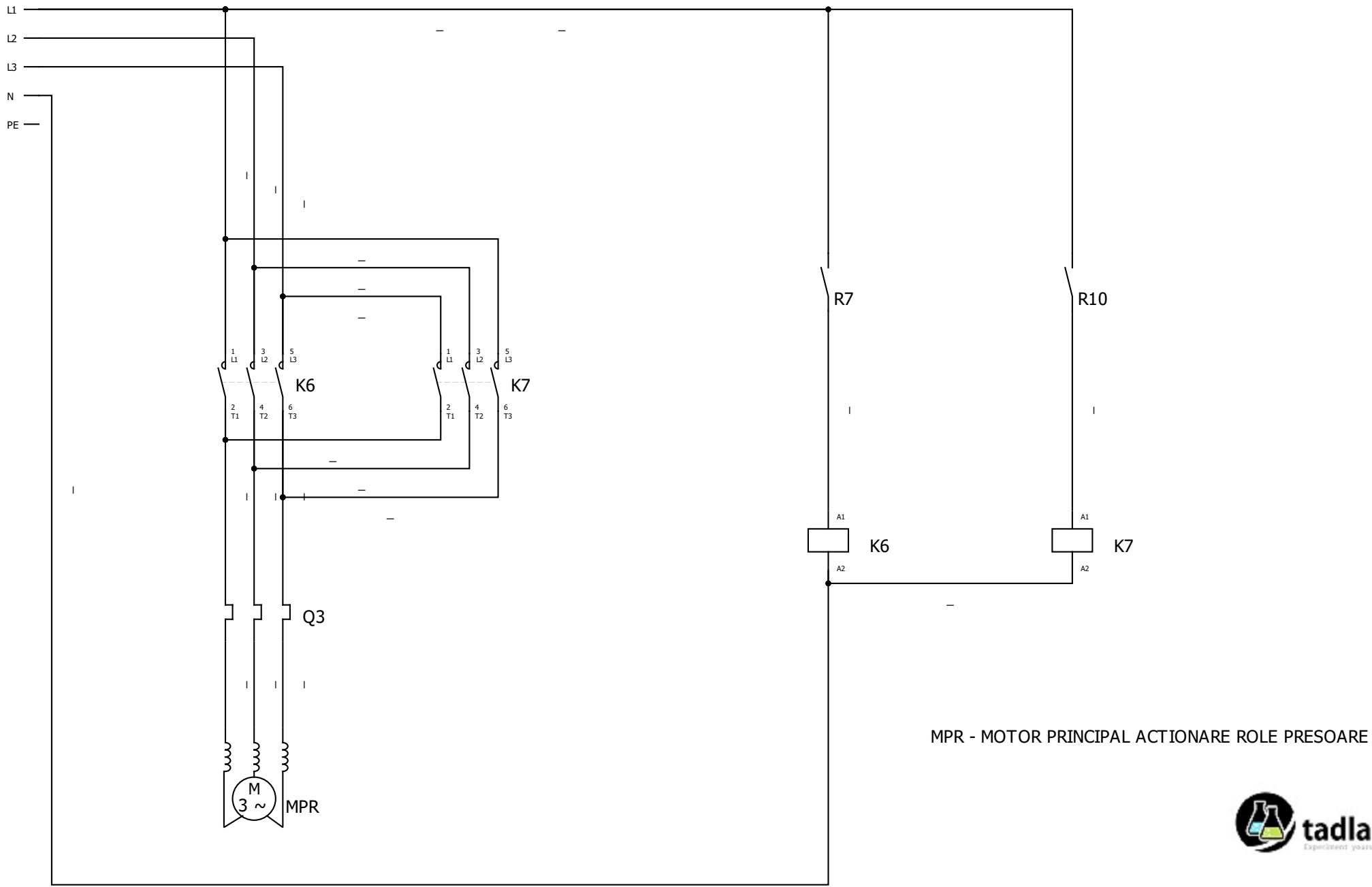

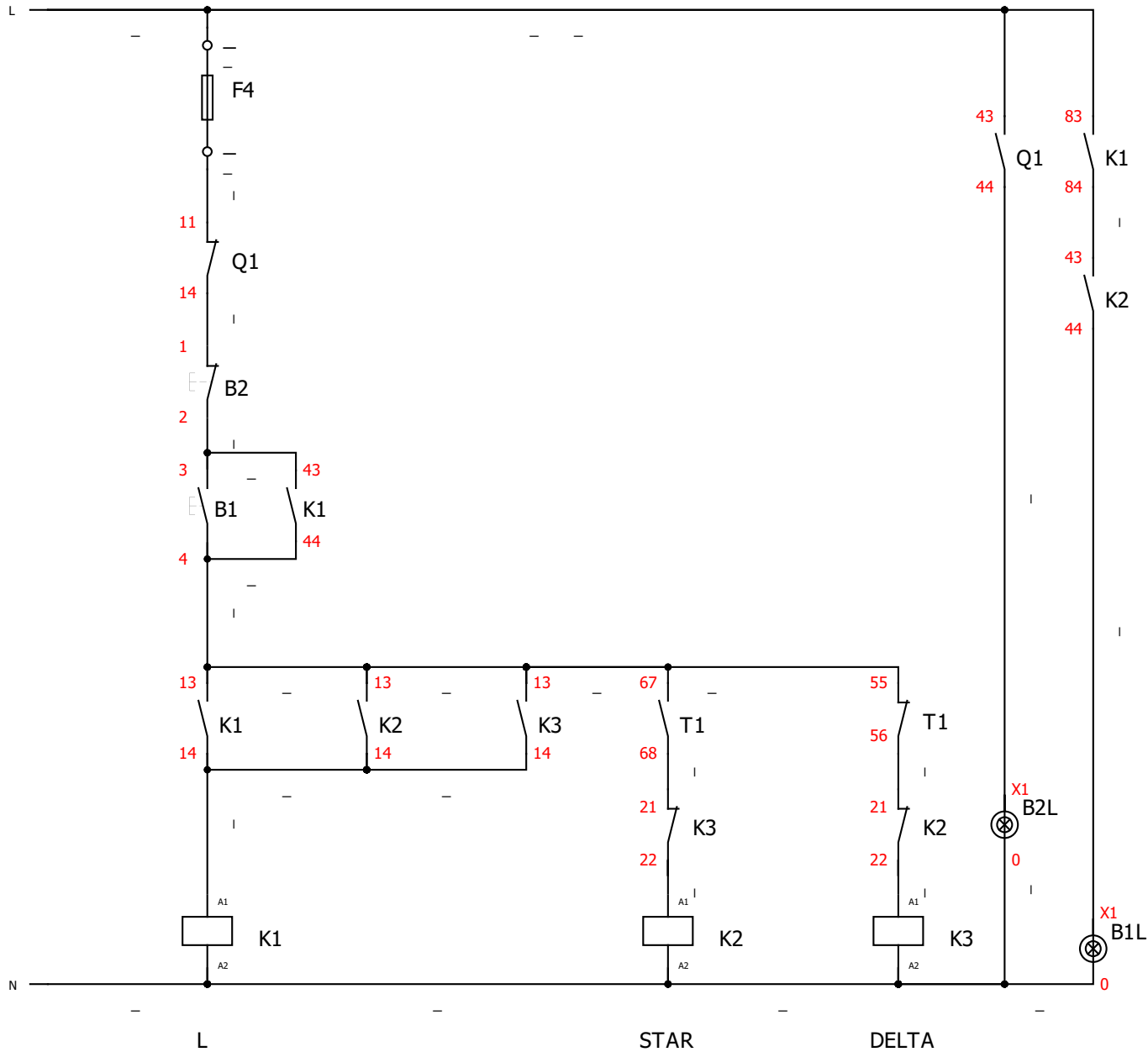

K1,K2,K3 - contactors with 3 poles , power supply of the coil = 220Vac;

T1 - mechanical timer relay at 220Vac;

F4 - used only for power coil of the contactors

FUNCTIONS:

- ensures the takeover of the switch by the line contactor by conditioning it with the closed state of the star contactor;
- in addition to the electrical interlock, the mechanical interlock of the delta and star contactors is also ensured;



Author: ING. TESU ADRIAN	STAR-DELTA STARTUP MMP by contacts	File: 1.2
Date: 5/24/2020		Folio: 5/13

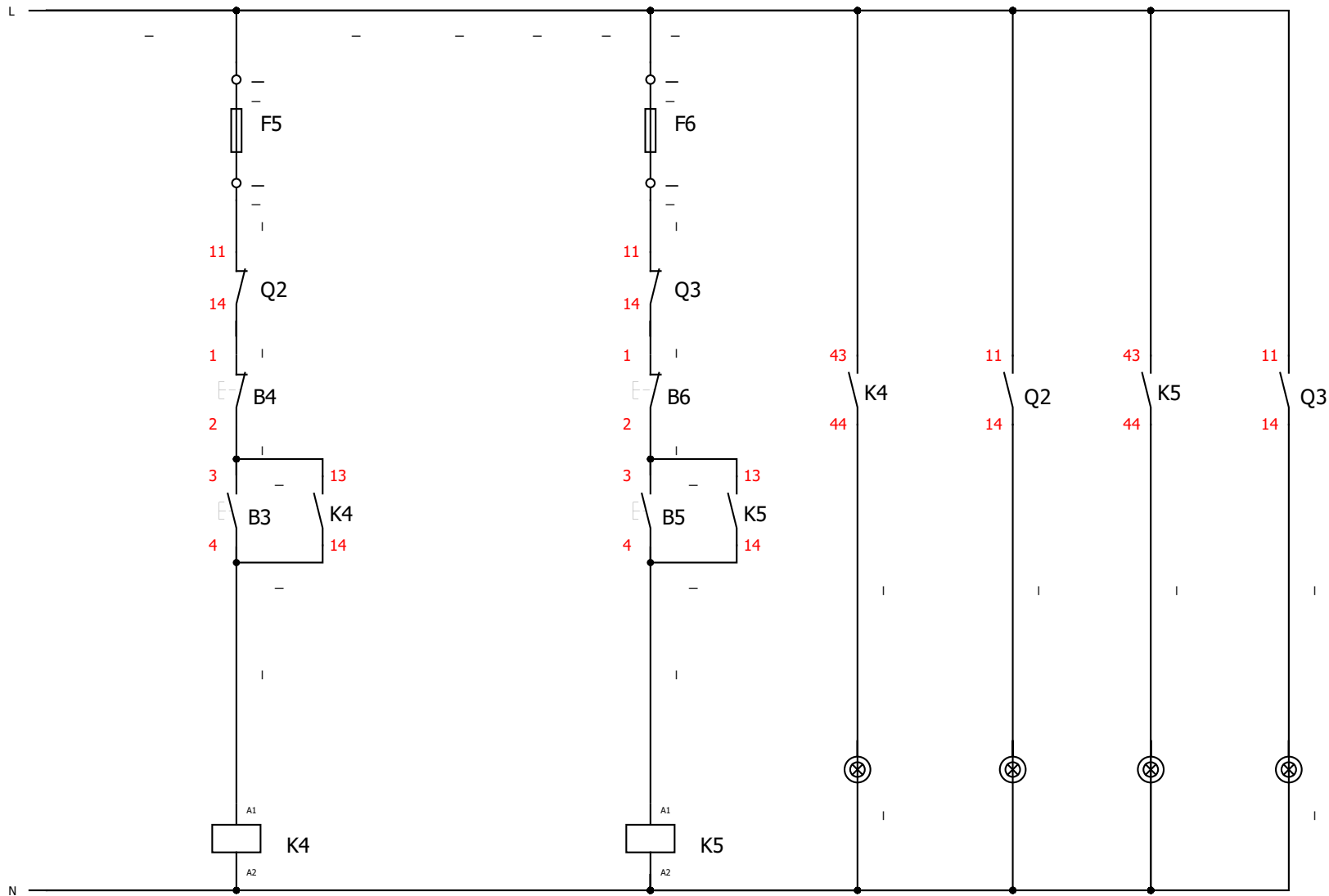

READING WITH FOLIO 1.1

RI - ENABLE AND START RELAY FOR VFD DRIVER



Author: ING. TESU ADRIAN	MOTORS CONTROL MMR-MH	File: 1.3
Date: 5/25/2020		Folio: 6/13

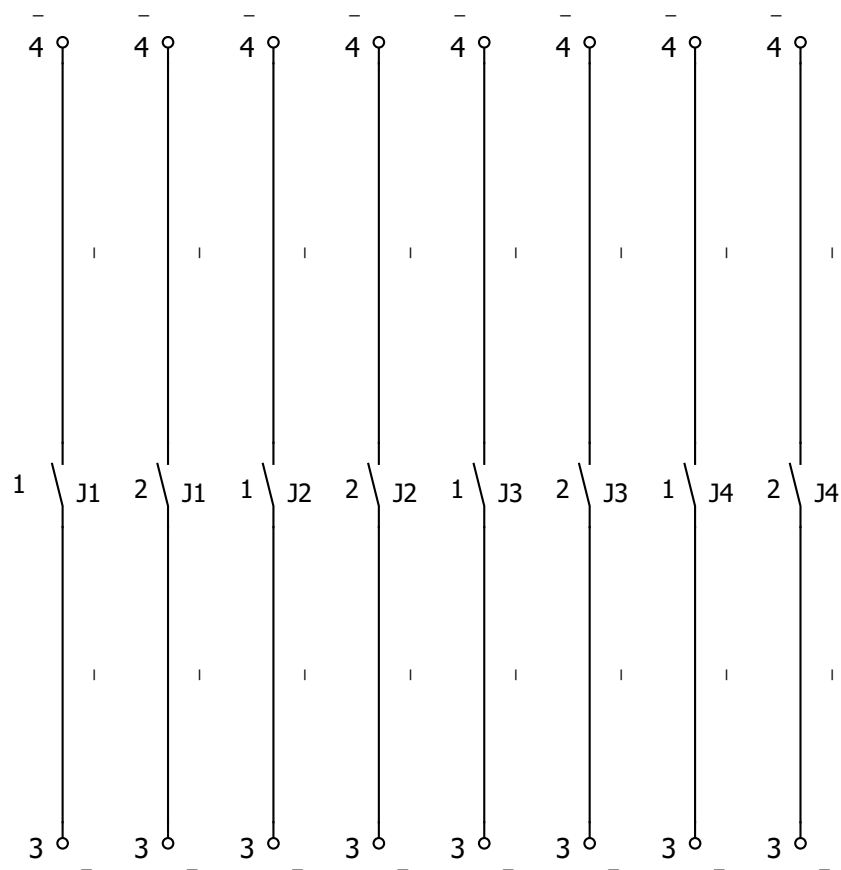

1J1 - MOVE LEFT SAW1
2J1 - MOVE RIGHT SAW 1

1J2 - MOVE LEFT SAW 2
2J2 - MOVE RIGHT SAW 2

1J3 - MOVE LEFT SAW 3
2J3 - MOVE RIGHT SAW 3

1J4 - MOVE UP ROLERS
2J4 - MOVE DOWN ROLERS



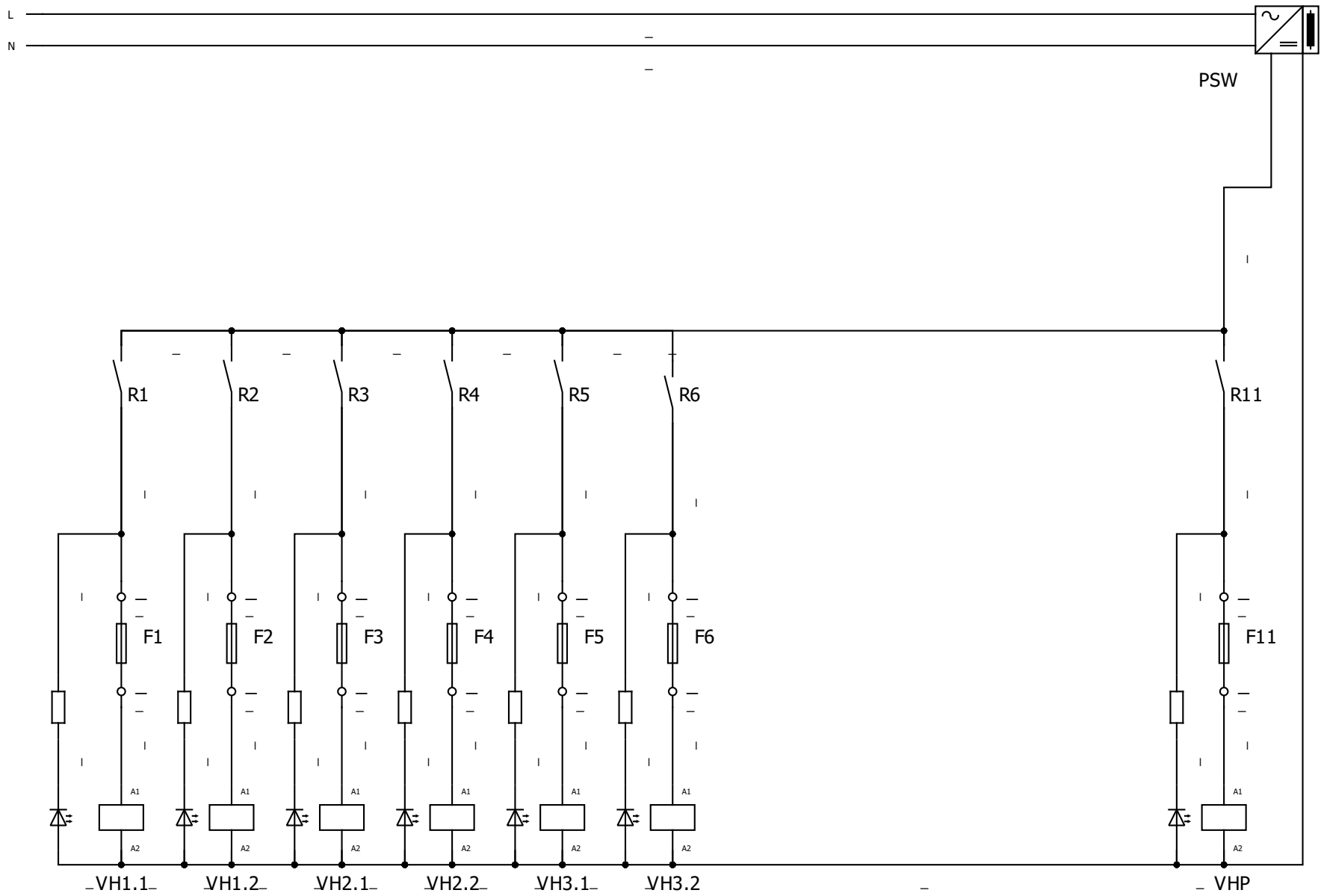

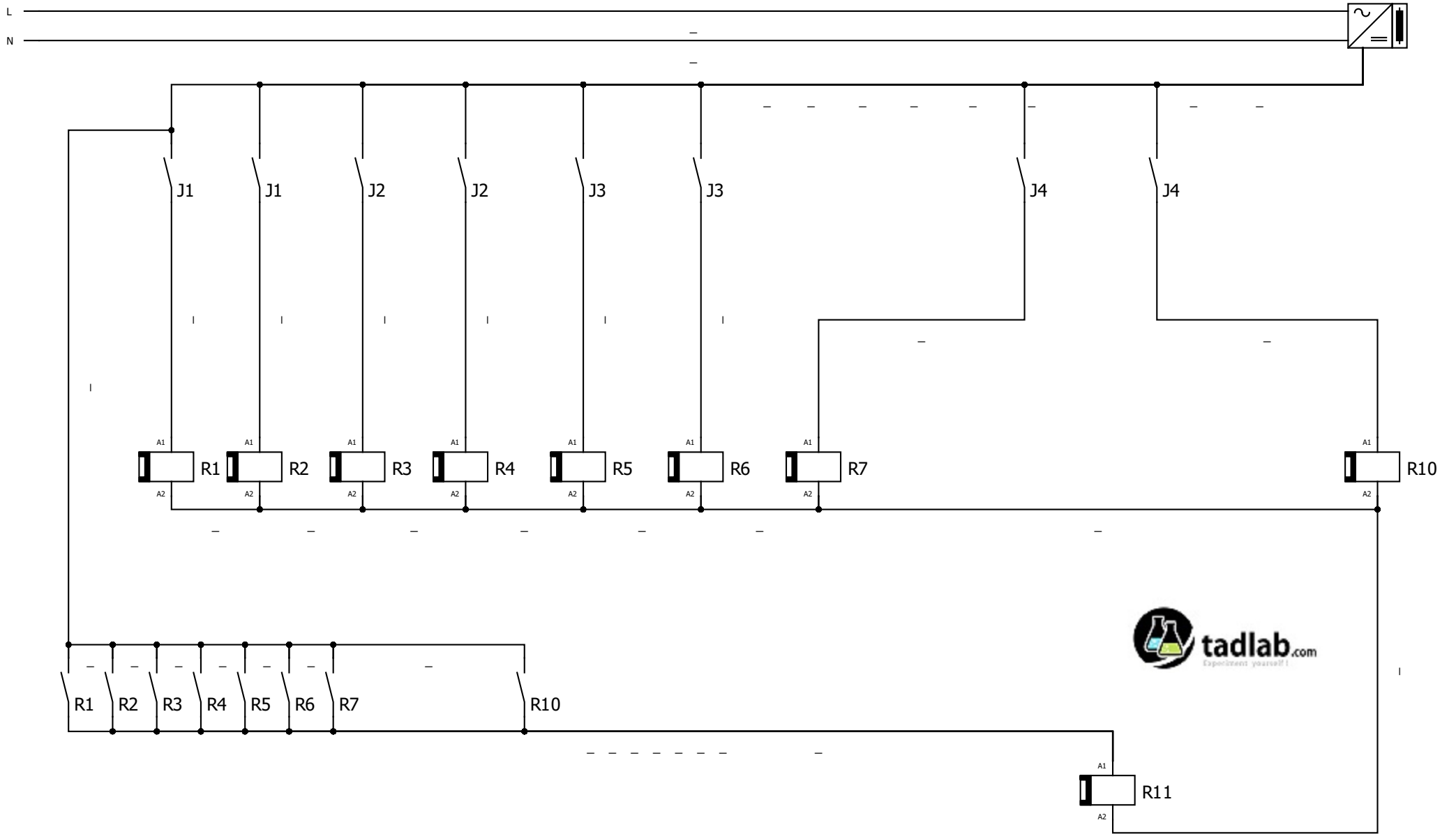

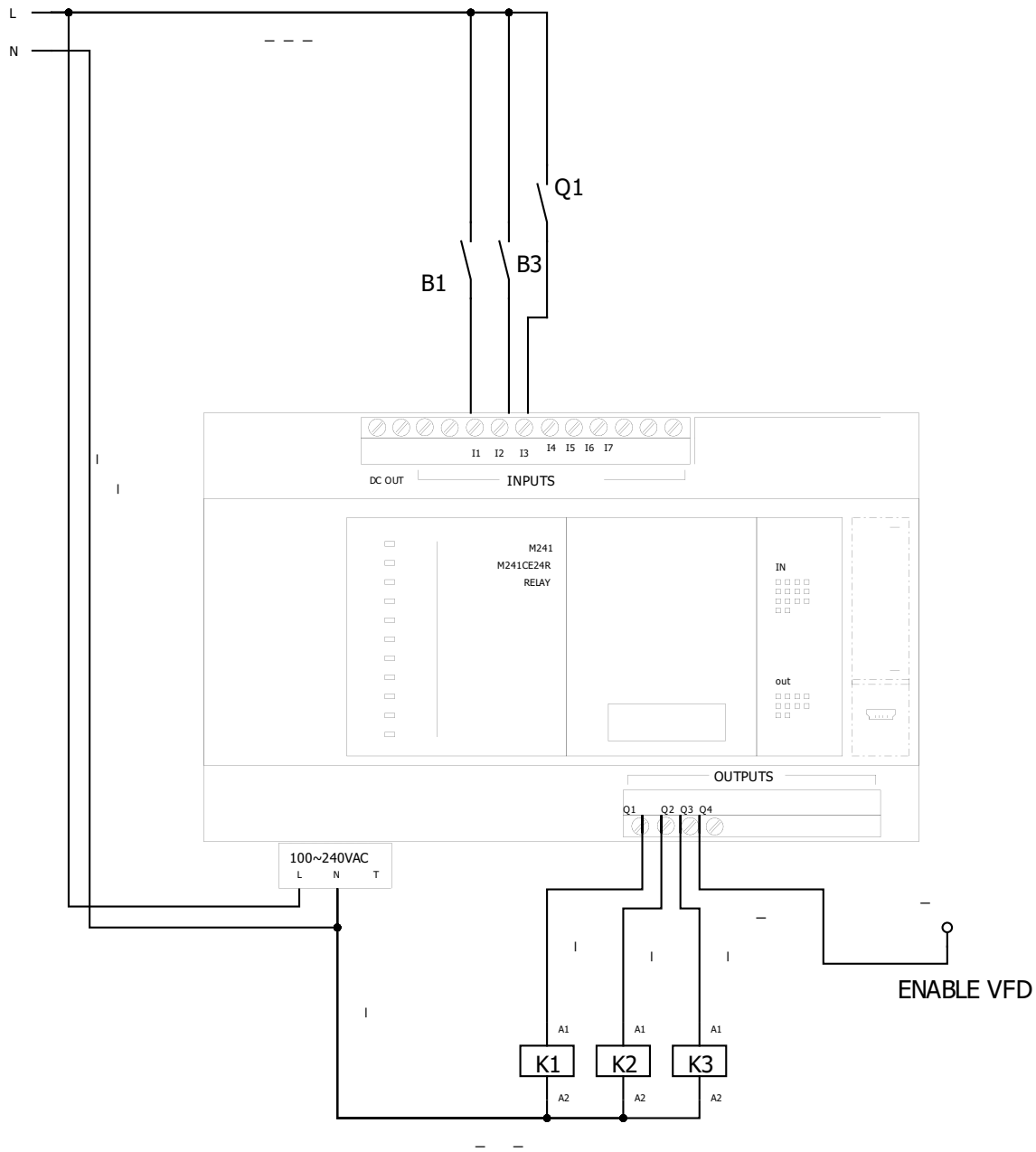

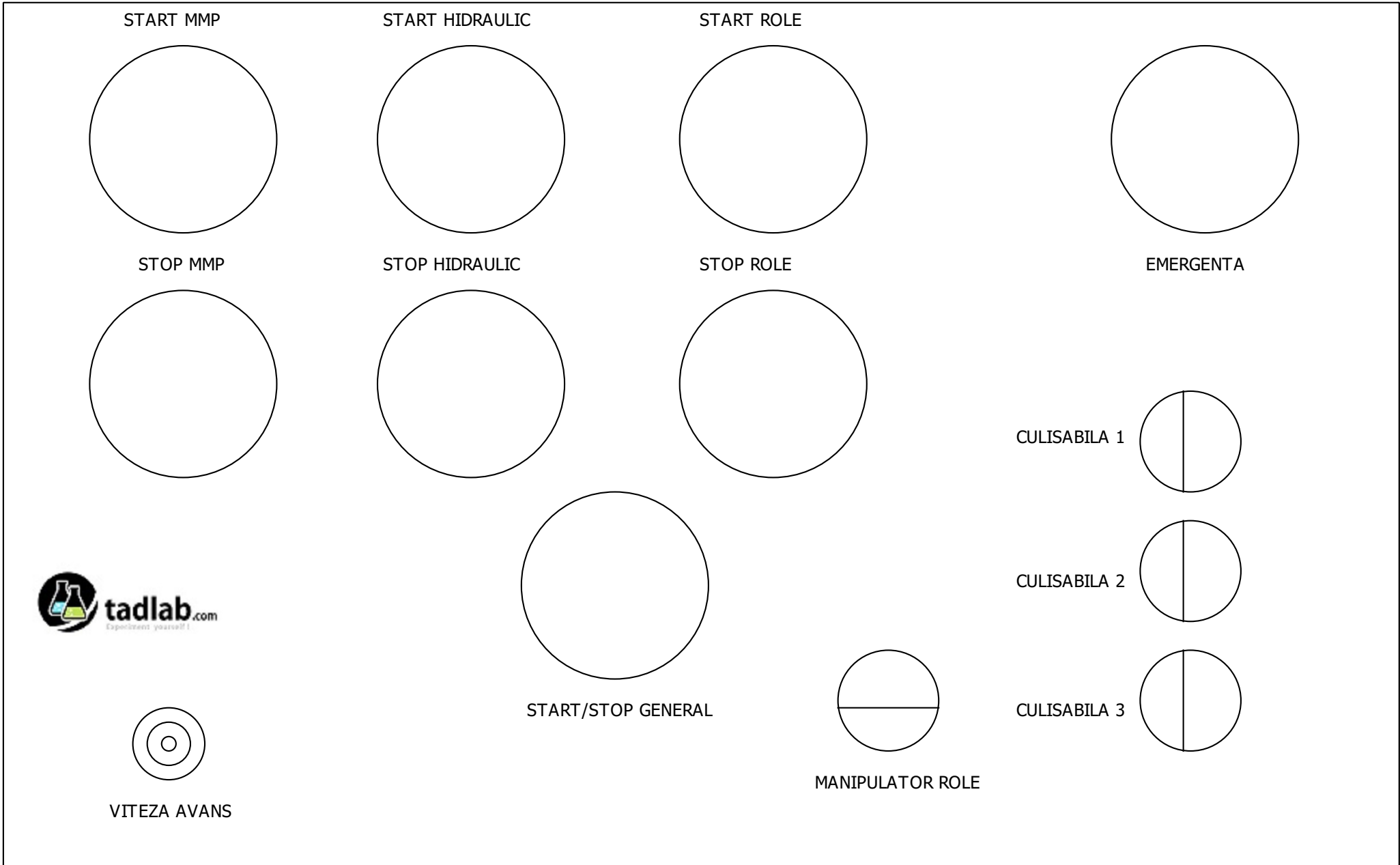

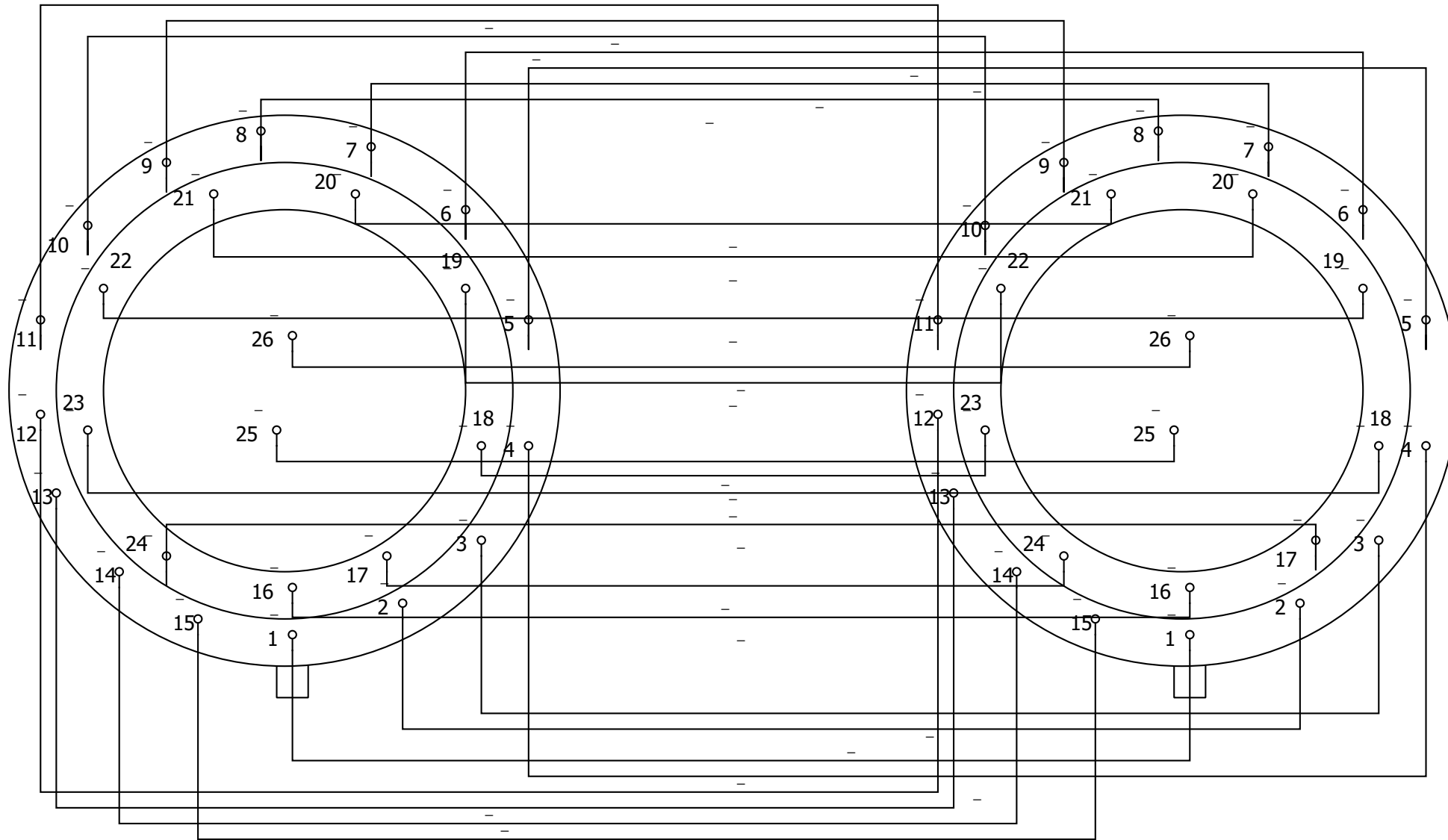

panel connector

main cable connector



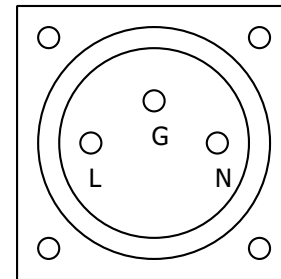
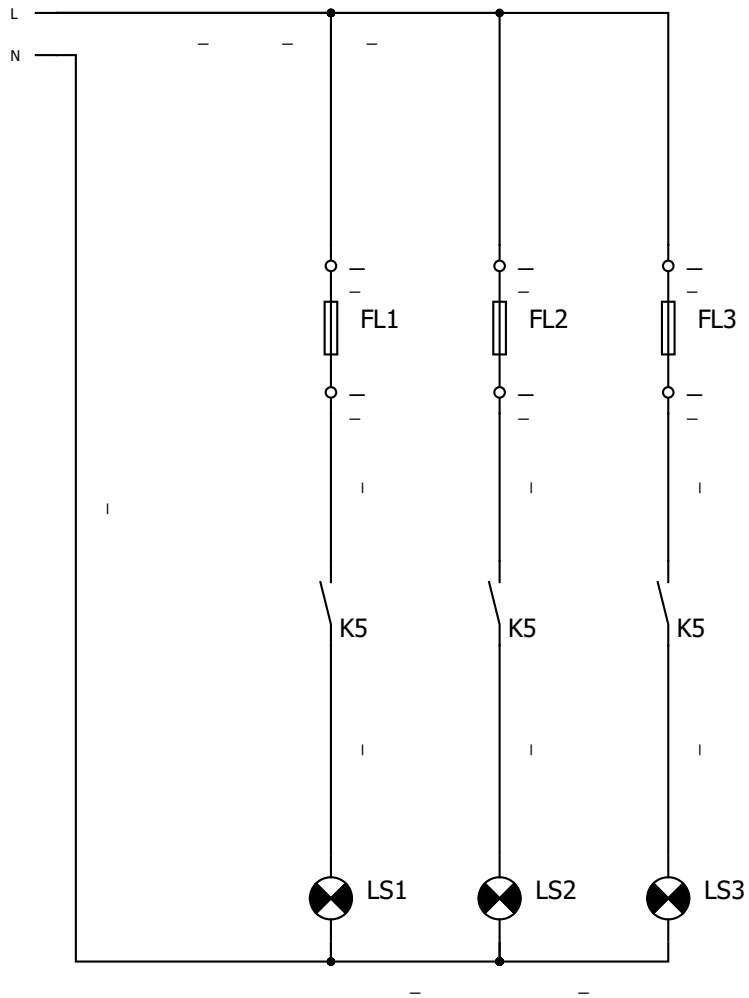

CONNECTOR TYPE